



## Vacuum Cleaner – Pow Air Vac (PAV) by GritSablare

### TECHNICAL DETAILS

#### Section 1. Technical Details

- Pow Air Vac by GritSablare is a manually operated vacuum system for cleanup of small amounts of residual blasting abrasive and/or dust.
  - Air powered – no electrical power required.
  - Powerful twin Venturi system for maximum efficiency.
  - Heavy duty ribbed 44 gallon (200 l) steel drum included.
  - 33 ft (10 m), wear resistant abrasive recovery hose.
  - 1-1/2" (38 mm) pick up wand standard.
  - Recovers steel grit at up to 2200 lbs (1000 kg) per hour.
  - Supply air required: 150 cfm (71 l/second) at 100 psi (690 kPa).
  - Shutoff ball valve standard.
  - Replaceable discharge dust bag.
- Common applications
  - Reduce costs by recovering and recycling expensive abrasives.
  - Reduce clean up operations.

#### Section 2. Complementary products

- BP50-1 Blasting Pot by GritSablare
- BP110-1 Blasting Pot by GritSablare
- BP316-1 Blasting Pot by GritSablare
- BP600 Blasting Pot by GritSablare
- Galaxy by GritSablare Blast Helmet
- AER215 Nuovo Blaster by GritSablare
- ProFlo Recycling System
- UltraFlo Recycling System



### Section 3. Assemblies, Part listing, Exploded View

#### Pow Air Vac Assembly

Code	Description	Quantity
BEC-RV-PB-0001	Pow Air Vac Assembly (Includes Items 1~21)	43kg (94.8lbs)
BEC-RV-0127-00	Pow Air Vac Top Assembly (Includes Items 1~20)	23.5kg (51.8lbs)
BAC-RV-0187-00	Pow Air Vac Top Head (Includes Items 1~17)	18kg (39.7lbs)
BAC-RV-PB-0018	Pow Air Vac Drum Clamp Kit (Item22) (Optional)	10kg (22lbs)

#### Pow Air Vac Parts Listing

Item	Code	Description	Quantity
1	YAC-RV-PB-0002	PAV Lid	1
2	YAC-RV-PB-0003	PAV Air Jet	2
3	YAC-RV-PB-0004	PAV Manifold	1
4	YAC-RV-PB-0005	PAV Venturi	2
5	YAC-RV-PB-0006	PAV Venturi Cover	1
6	YAC-RV-PB-0007	PAV Cage	1
7	BAC-RV-PB-0008	Dust Bag	1
8	YAC-FN-PB-0156	Hose Clamp	1
9	YAC-PF-0270-00	Nipple	1
10	YAC-FN-PB-0073	Screw	3
11	YAC-FN-PB-0038	Flat Washer	3
12	YAC-FN-PB-0051	Spring Washer	3
13	YAC-FN-PB-0012	Hex Head Bolt	4
14	YAC-FN-PB-0007	Flat Washer	4
15	YAC-FN-PB-0008	Spring Washer	4
16	BAC-PF-PB-0004	19mm (3/4") Ball Valve	1
17	YCS-RV-0126-00	Foam Rubber	2 MTR
18	BAC-RV-PB-0013	Pow Air Vac Hose. 10M	1
19	YAC-FN-PB-0074	Hose Clamp	2
20	YAC-RV-PB-0012	PAV Pick Up Wand	1
21	YAC-RV-PB-0014	PAV Drum	1

### Pow Air Vac Exploded View

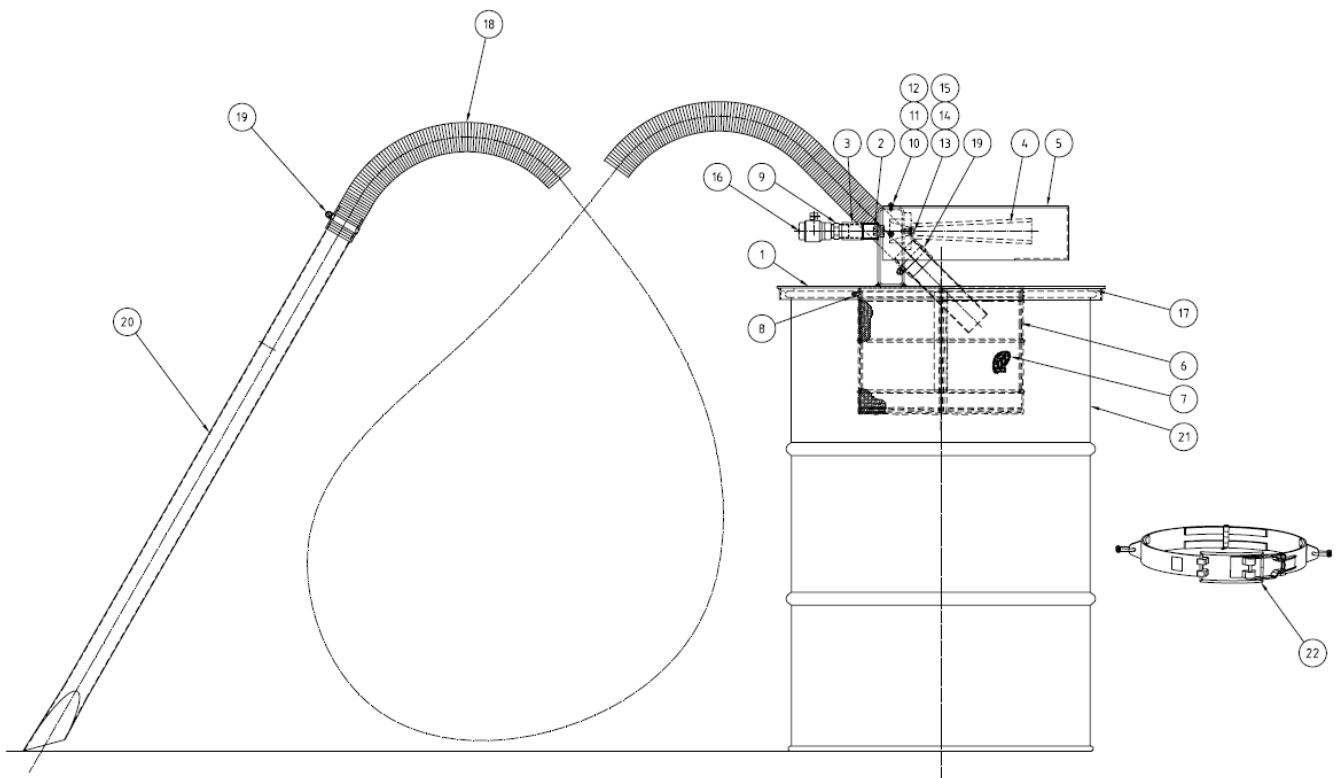
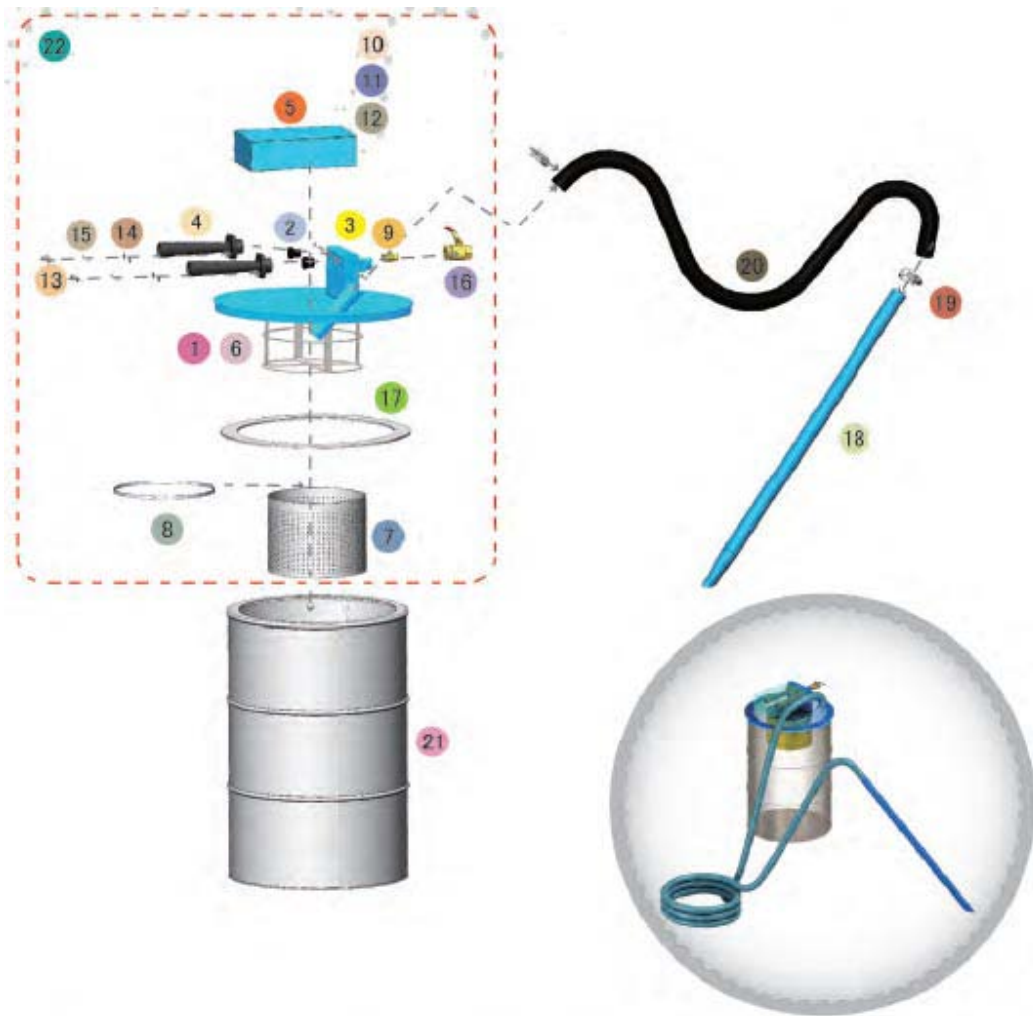



## Section 4. Product Operating Manual

### 1. General Information

#### 1.1. GritSablare notice to purchasers and users.

1.1.1. All products and equipment provided by GritSablare are intended for use by experienced users of abrasive blasting equipment and its associated operations and abrasive blasting media.

1.1.2. It is the responsibility of the user to:

- Determine if the equipment and abrasive media is suitable for the users' intended use and application.
- Familiarize themselves with any appropriate laws, regulations and safe working practices which may apply within the users' working environment.
- Provide appropriate operator training and a safe working environment including operator protective equipment such as, but not limited to, blasting suit, safety footwear, protective eyewear and hearing protection.

1.1.3. GritSablare Standard Terms and Conditions of Sale apply. Contact us should you require any further information or assistance.

#### 1.2. **! WARNING! – Read this section carefully before using this equipment**

1.2.1. Heavy metal paint, asbestos and other toxic material dusts will cause serious lung disease or death without the use of properly designed and approved supplied air respiratory (SAR) equipment by blast operators and all personnel within the work site area

1.2.2. The compressor must have adequate output and the plumbing between the compressor and the point of attaching the air supply hose must have sufficient capacity to supply the volume of air at the pressure required.

#### 1.3. Standard safety precautions

1.3.1. Approved safety eyewear, hearing and footwear protection should be worn at all times by the operator and anyone else in the immediate area that may be exposed to any hazards generated by the abrasive blasting process.

1.3.2. Suitably approved respiratory protection (PPE) should also be worn when handling abrasive media, abrasive refuse dust and when carrying out any service/maintenance work where any dust may be present.

1.3.3. Any work performed on electrical wiring or components must only be carried out by suitably qualified and registered electrical trade's personnel.

1.3.4. Under no circumstances should any safety interlocks / lockouts or features be altered or disabled in any way.

1.3.5. All equipment must be isolated from the compressed air supply and electrical power source prior to any service or maintenance work being carried out.

1.3.6. All care must be taken by the operator when lifting or moving equipment or components in order to prevent injury. Pressure Blast Pots must always be emptied of abrasive media before any attempt is made to move them.

1.3.7. Any modification of the equipment or use of non-genuine GritSablare replacement parts will void warranty.

1.3.8. Always check the Material Safety Data Sheet (MSDS) on the abrasive being used to ensure that it is free of harmful substances, in particular, free silica, cyanide, arsenic or lead.

1.3.9. Test the surface to be blasted for harmful substances, taking the appropriate measures to ensure the safety of all personnel.



- 1.3.10. The operator should carry out a daily inspection of all related components prior to startup of all wearing and safety items to ensure they are in correct operating order. In particular check all Hose Couplings and Nozzle Holders, ensuring that all Hose Couplings are fitted correctly, the Safety Pins are engaged and in good order. Always install Safety Whip Check Cables at every hose connection. Ensure that the Blast Nozzle has been securely screwed into the Nozzle Holder and the Nozzle Holder has been secured to the Blast Hose correctly and all screws are engaged.

## 2. Introduction

- 2.1. These instructions cover the installation, operation and maintenance of the GritSablare Pow Air Vac abrasive recovery system.
- 2.2. The GritSablare Pow Air Vac is designed to perform recovery of any commercial abrasive from expendable abrasives through to aggressive metallic abrasives such as steel grit.

## 3. Preparation for Operation

- 3.1. Ensure that the Dust Bag is securely fastened in the correct position located on the underside of the Top Lid.
- 3.2. Place the Top Lid onto the supplied abrasive storage drum and ensure that the Top Lid is fully sealed around the drum circumference.
- 3.3. Attach one end of the abrasive Recovery Hose to the abrasive vacuum spigot located on the Top Lid. Attach the opposite end of the abrasive Recovery Hose to the abrasive pick up wand. Securely fasten both ends of the abrasive Recovery Hose with the provided hose clamps.
- 3.4. Attached a suitable main air supply hose (not supplied) to the 19mm (3/4") main air inlet ball valve located on the Top Lid. It is recommended a suitably sized air supply line of 19mm (3/4") ID or larger be utilized to supply the Pow Air Vac system. Ensure that coupling safety Locking Pins and Safety Whip Checks are utilized at each hose connection point.

**NOTE: THE MINIMUM COMPRESSED AIR SUPPLY REQUIRED TO OPERATE THE POW AIR VAC SYSTEM IS 71 LITRES/SECOND (150 CFM) AT 690KPA (100 PSI).**

## 4. Operating Instructions

**! WARNING! – READ THIS SECTION CAREFULLY BEFORE USING THIS EQUIPMENT APPARATUS.**

- 4.1. Ensure that the 19mm (3/4 ) air inlet ball valve located on the Top Lid is in the isolated closed position.
- 4.2. Slowly turn on your compressed air supply source.
- 4.3. To commence the abrasive recovery process, slowly turn the 19mm (3/4) air inlet ball valve on the Top Lid cover to the open position.
- 4.4. Position the tapered end of the abrasive pick up wand as close as possible to the abrasive and commence the abrasive recovery process.

**NOTE: NEVER ISOLATE, CLOSE OR BLOCK THE AIR BREATHER HOLE LOCATED ON THE ABRASIVE PICK UP WAND. ISOLATING THE AIR BREATHER HOLE WILL IMPAIR THE VACUUM FUNCTION.**

- 4.5. To stop the abrasive recovery operation, close the 19mm (3/4") air inlet ball valve located on the Top Lid cover.

**! WARNING! – IT IS RECOMMENDED THAT APPROVED HEARING PREOTECTION IS WORN DURING THE OPERATION OF THIS EQUIPMENT/APPARATUS.**

## 5. Maintenance

**! WARNING! – THE COMPRESSED AIR SOURCE MUST BE ISOLATED BEFORE PERFORMING ANY MAINTENANCE WORK. FAILING TO DO SO MAY CAUSE SERIOUS INJURY OR DEATH.**

- 5.1.** Periodically remove the Dust Bag from the Top Lid and blow down with dry compressed air. The Dust Bag may also be washed in water with a mild detergent and air dried. Replace the dust bag if any holes or if any excessive reduction of the vacuum suction is detected.
- 5.2.** Check the abrasive Recovery Hose after each operation for any signs of cracks, holes or wear. It is recommended that the abrasive Recovery Hose be kept as straight as possible and horizontal during the vacuum recovery operation. Avoid sharp radius bending of the abrasive Recovery Hose during operation to extend the service life of the abrasive Recovery Hose.
- 5.3.** Inspect the abrasive pick up wand and remove any debris that may be caught in the abrasive pick up wand section prior to each operation.

**! WARNING! – NEVER ATTEMPT TO PICK UP OR MOVE THE DRUM DURING OR AFTER OPERATION AS IT MAY CAUSE SERIOUS INJURY. OPTIONAL BAC-RV-PB-0018 (DRUM CLAMPING KIT) IS AVAILABLE FOR EASE OF DRUM RELOCATION.**

## 6. Trouble shooting

Problem	Problem solution
System not recovering the abrasive media	<ul style="list-style-type: none"> <li>▪ Check if the incoming compressed air supply meets the minimum air supply requirement.</li> <li>▪ Check the breather hole on the abrasive pick up wand is not obstructed.</li> <li>▪ Check the dust bag and ensure that it is not blocked with fine dust. Clean or replace the dust bag.</li> <li>▪ Check the recovery hose for any wear. Replace if necessary.</li> <li>▪ Check the pick up wand and remove any oversize debris that may have been caught during operation.</li> </ul>

### Section 5. Product Identification

Product name	Vacuum Cleaner – Pow Air Vac (PAV) by GritSablare
Distributor:	<b>GritSablare</b>
	Headquarter: 10 Eliza Zamfirescu Leonida Street, Bucharest
	Storage & Logistic: Constanța Seaport, Gate 2, SORENA Platform, Constanța, Romania
	Phone: (+4) 0722.279.481
	Email: comercialgritsablare@gmail.com
	Website: www.gritsablare.ro