



Tel: +4 0722 279 481
+4 0725 984 004

Email: comercialgritsablare@gmail.com
Web: www.gritsablare.ro

Sustainable Solutions for Blasting & Cleaning
Dedicated Line for Professional Blasting Equipment

Blasting Room and Paint Room, Retractable System Cortina by GritSablare

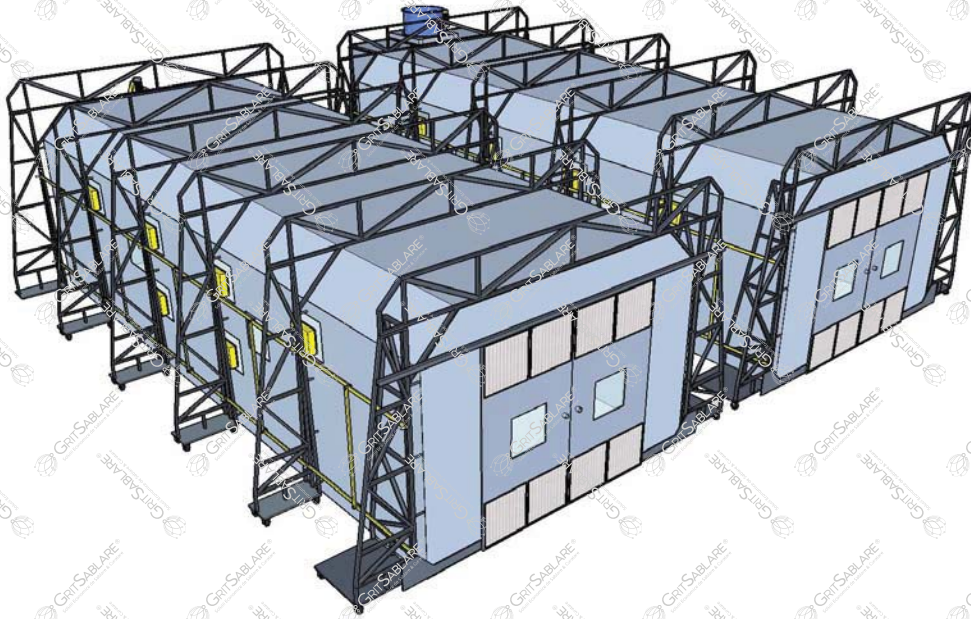

- Cortina / retractable system - saving on factory floor space when blasting or coating procedures are not required.
- Portability - Able to easily relocate and position to meet with all project requirements.
 - Fabric Enclosure Material - Fire Resistant
 - Internal Walls - Rubber Lining for extended service life
 - Main Entry Doors - Full access sliding type
 - Room Lighting - LED
 - Blast Room Ventilation System - In compliance with International Standards
 - Paint Room Extraction System - In compliance with International Standards

Section 1. Company Identification

Distributor:

GritSablare

Headquarter:

10 Eliza Zamfirescu Leonida Street, Bucharest

Storage & Logistic:

Constanța Seaport, Gate 2, SORENA Platform, Constanța, Romania

Phone:

(+4) 0722.279.481

Email:

comercialgritsablare@gmail.com

Website:

www.gritsablare.ro



Tel: +4 0722 279 481
+4 0725 984 004

Email: comercialgritsablare@gmail.com
Web: www.gritsablare.ro

Sustainable Solutions for Blasting & Cleaning
Dedicated Line for Professional Blasting Equipment

NOTE: ALL SIZES ARE PROVISIONAL AND WILL BE CONFIRMED ON FINAL DESIGN

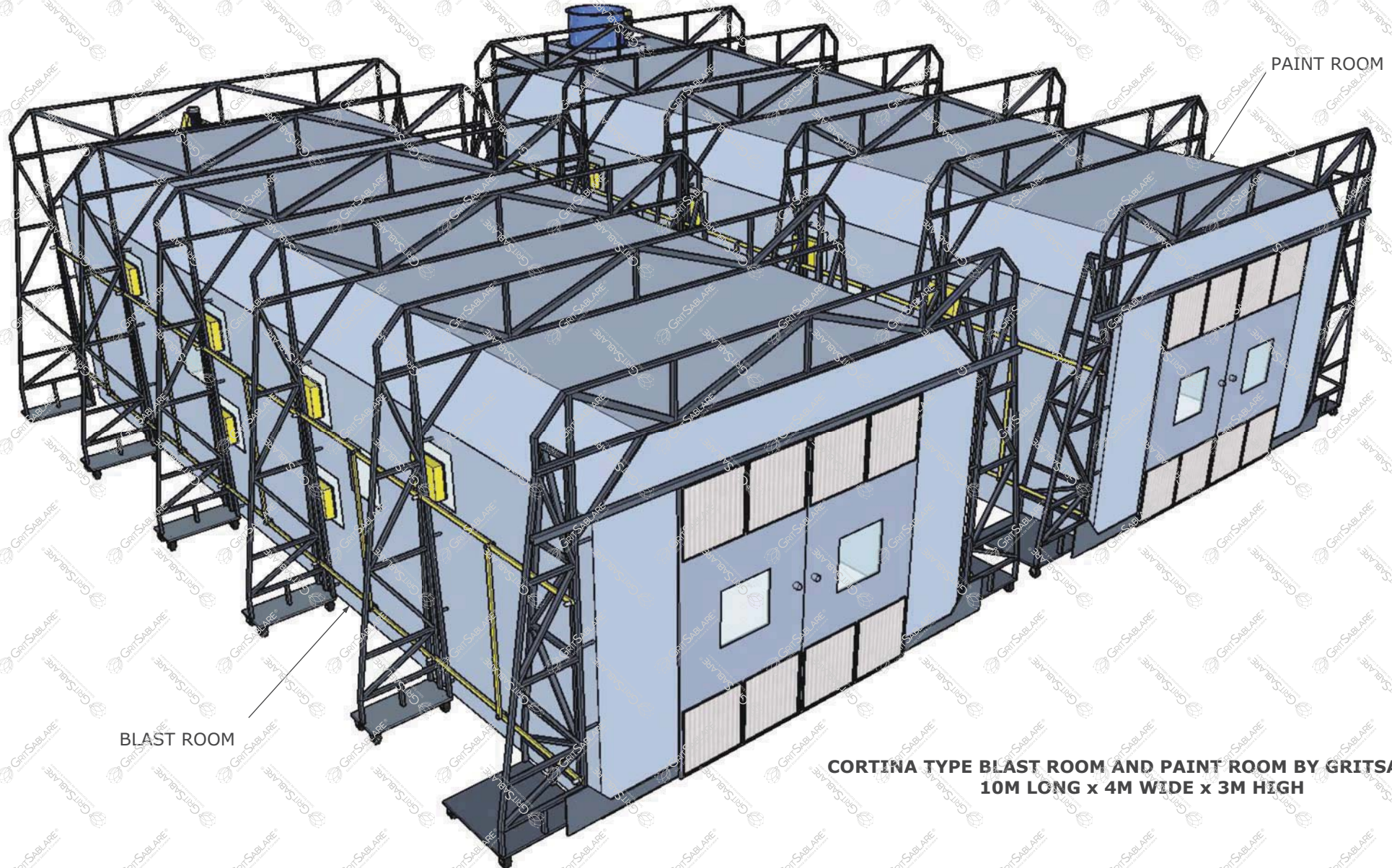

**CORTINA TYPE BLAST ROOM AND PAINT ROOM BY GRITSABLARE
10M LONG x 4M WIDE x 3M HIGH**



Tel: +4 0722 279 481
+4 0725 984 004

Email: comercialgritsablare@gmail.com
Web: www.gritsablare.ro

Sustainable Solutions for Blasting & Cleaning
Dedicated Line for Professional Blasting Equipment

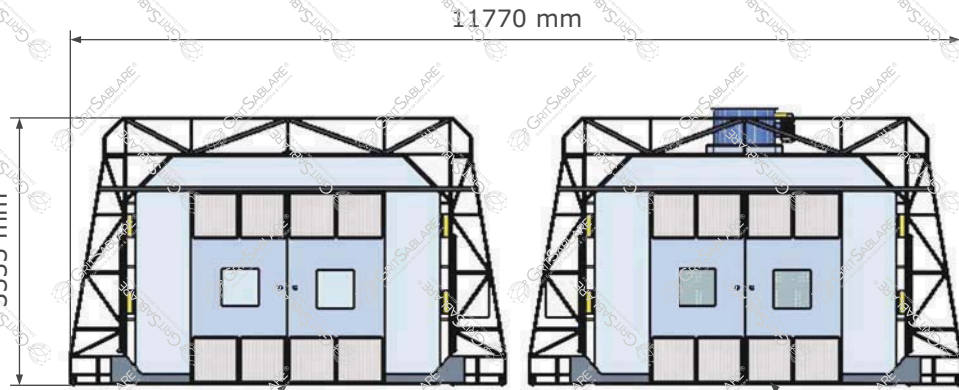

BLAST ROOM

PAINT ROOM

FRONT VIEW

BLAST ROOM AND PAINT ROOM LAYOUT

CONTROL PANELS

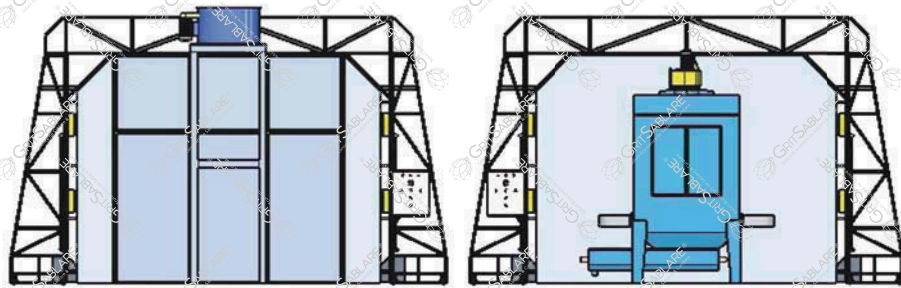

BACK VIEW

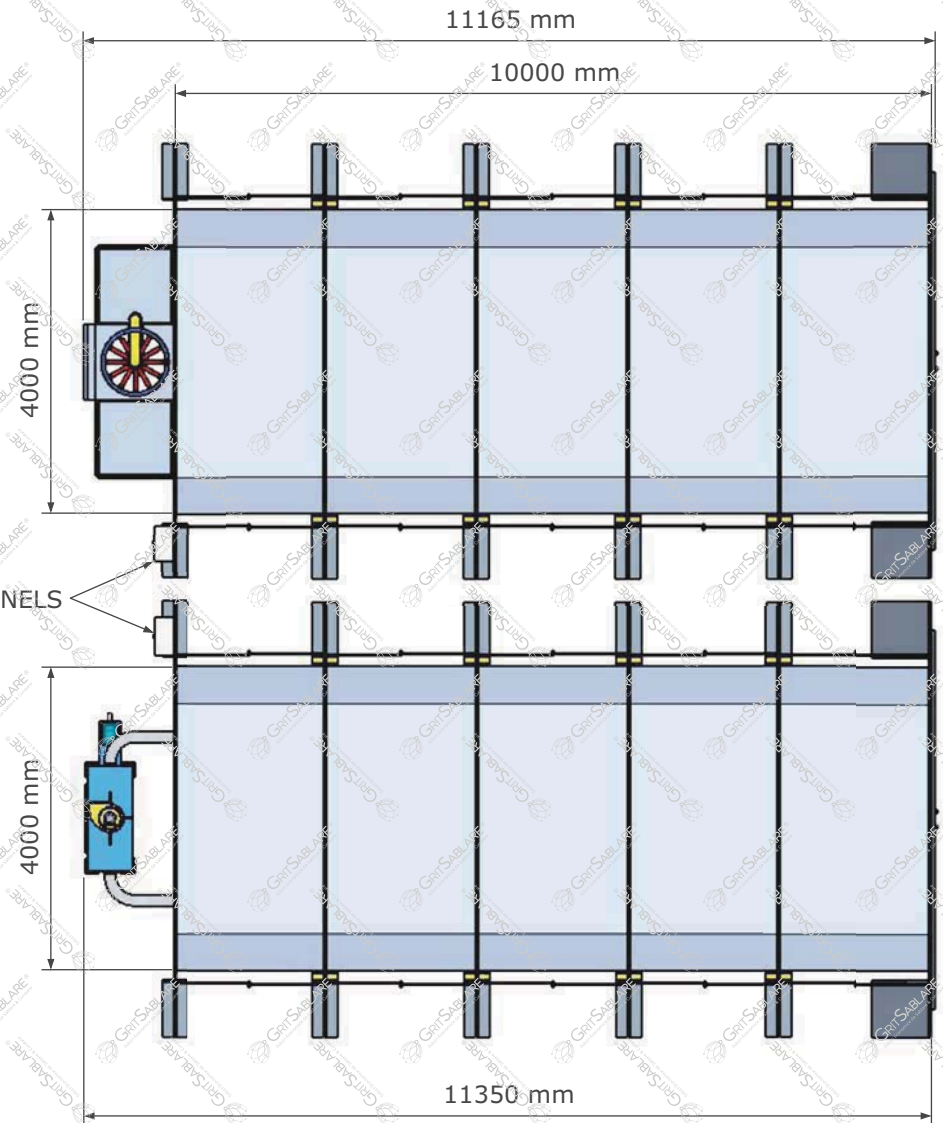

PLAN VIEW



Tel: +4 0722 279 481
+4 0725 984 004

Email: comercialgritsablare@gmail.com
Web: www.gritsablare.ro

Sustainable Solutions for Blasting & Cleaning
Dedicated Line for Professional Blasting Equipment

| PRODUCT DETAILS | |
|-----------------|------------------|
| REFERENCE DWG | SI 423 |
| POWER SUPPLY | 415V, 3PH, 50 HZ |
| POWER REQUIRED | 6.7 kW |
| AIR REQUIRED | NA |

**PAINT ROOM DETAILS
(EXTENDED)**

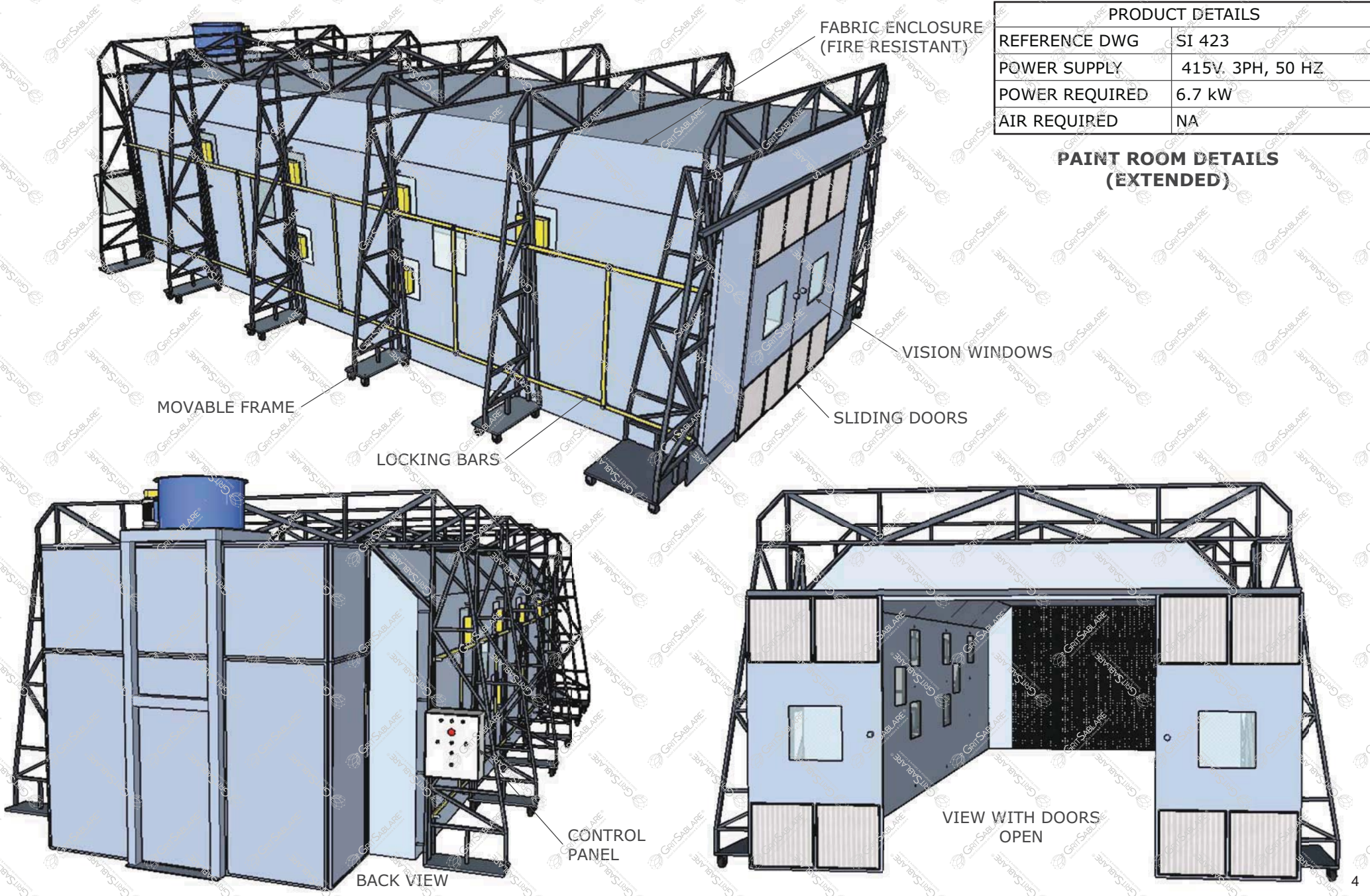



Tel: +4 0722 279 481
+4 0725 984 004

Email: comercialgritsablare@gmail.com
Web: www.gritsablare.ro

Sustainable Solutions for Blasting & Cleaning
Dedicated Line for Professional Blasting Equipment

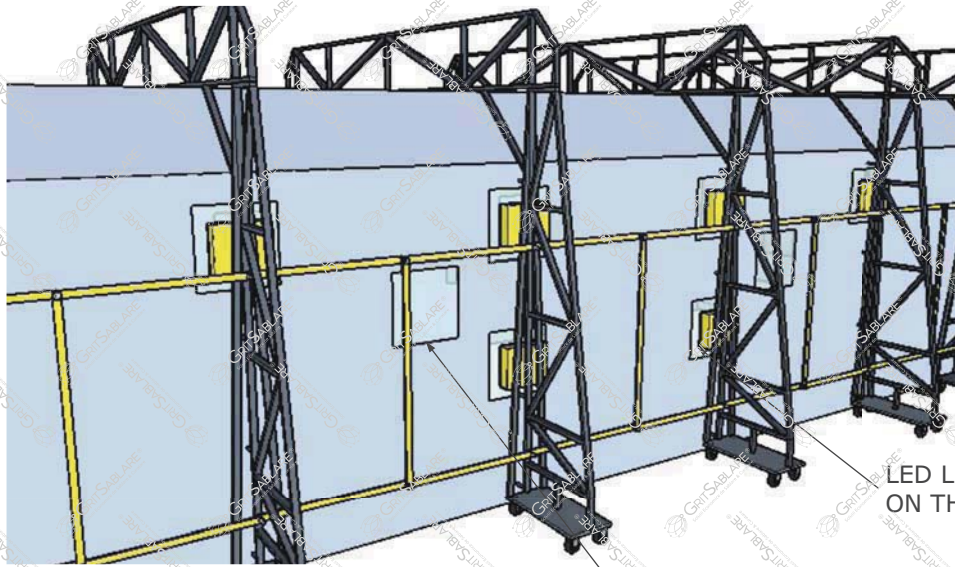

LED LIGHTS MOUNTED ON THE MOVABLE FRAMES

VISION WINDOWS



FAN

ANDREAE PAINT FILTERS

FRONT SECTION VIEW

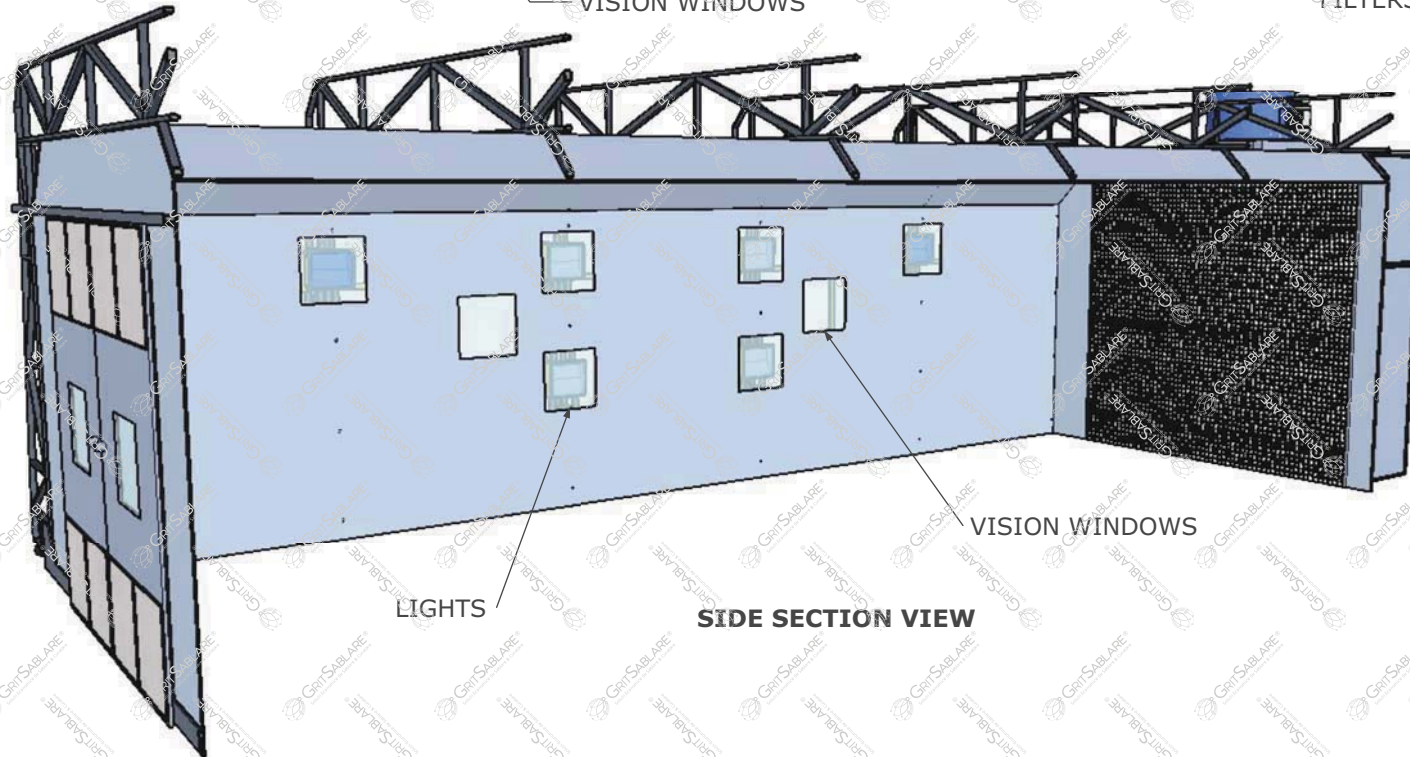

EXTRACTION CHAMBER

VISION WINDOWS

LIGHTS

SIDE SECTION VIEW

PAINT ROOM DETAILS
(EXTENDED)



Tel: +4 0722 279 481
+4 0725 984 004

Email: comercialgritsablare@gmail.com
Web: www.gritsablare.ro

Sustainable Solutions for Blasting & Cleaning
Dedicated Line for Professional Blasting Equipment

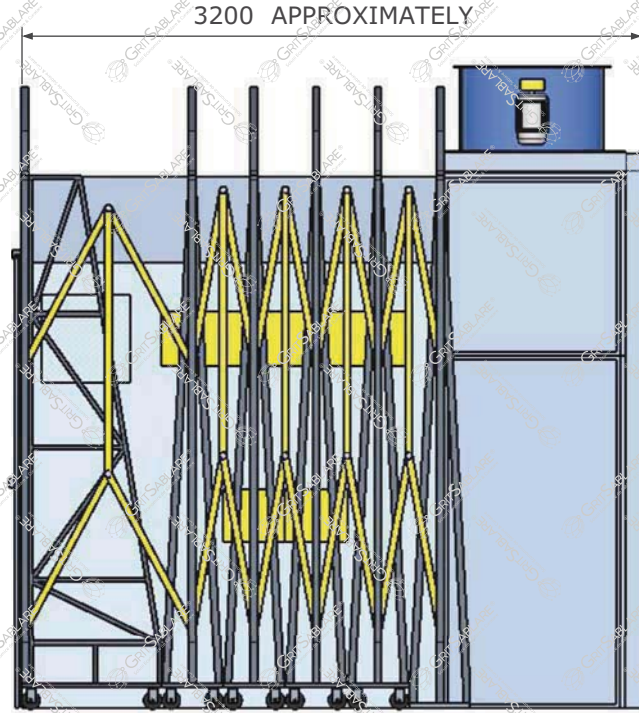
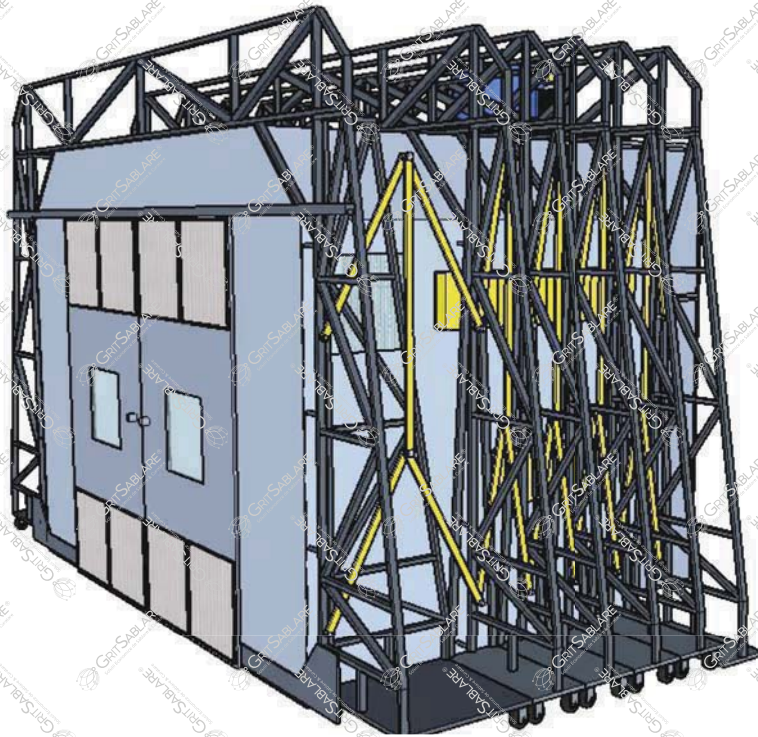

VIEWS OF PAINT ROOM
RETRACTED

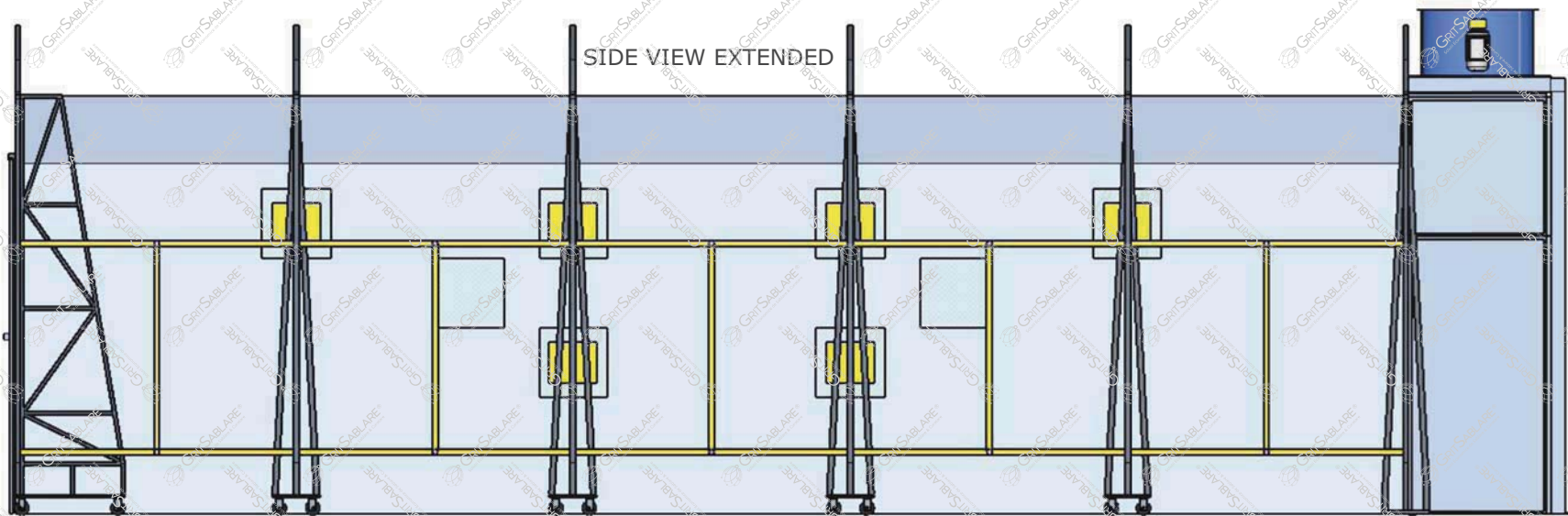

SIDE VIEW EXTENDED



Tel: +4 0722 279 481
+4 0725 984 004

Email: comercialgritsablare@gmail.com
Web: www.gritsablare.ro

Sustainable Solutions for Blasting & Cleaning
Dedicated Line for Professional Blasting Equipment

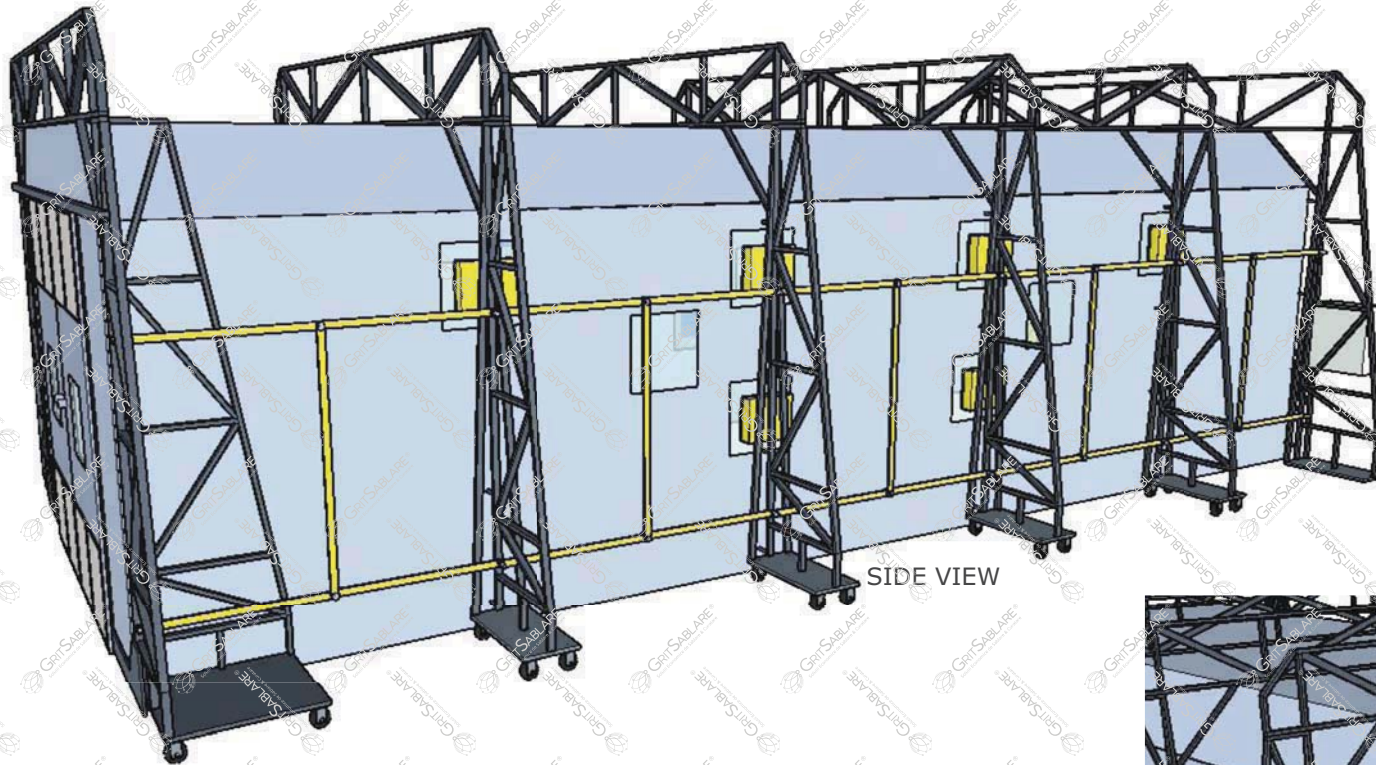

SIDE VIEW

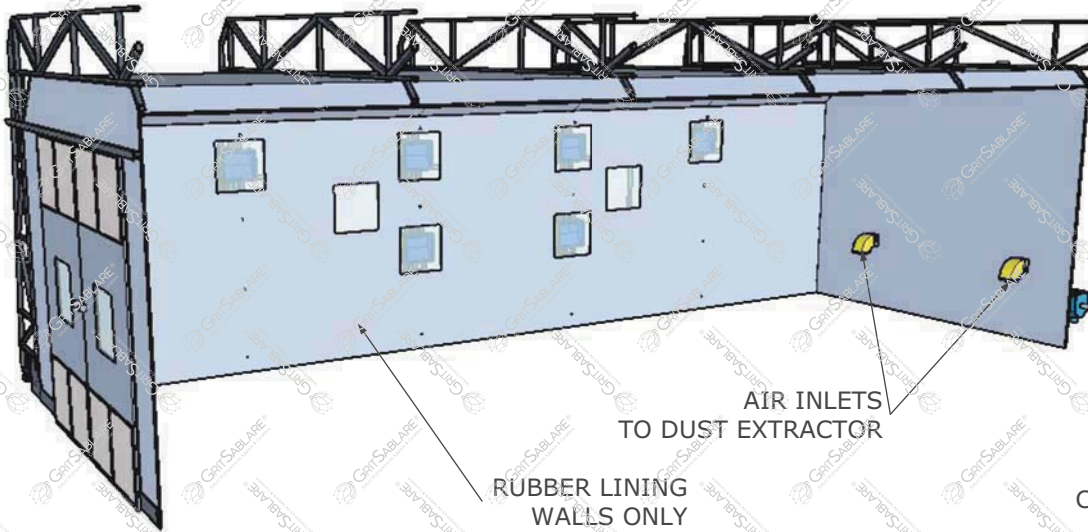

SIDE SECTION VIEW

AIR INLETS
TO DUST EXTRACTOR

RUBBER LINING
WALLS ONLY

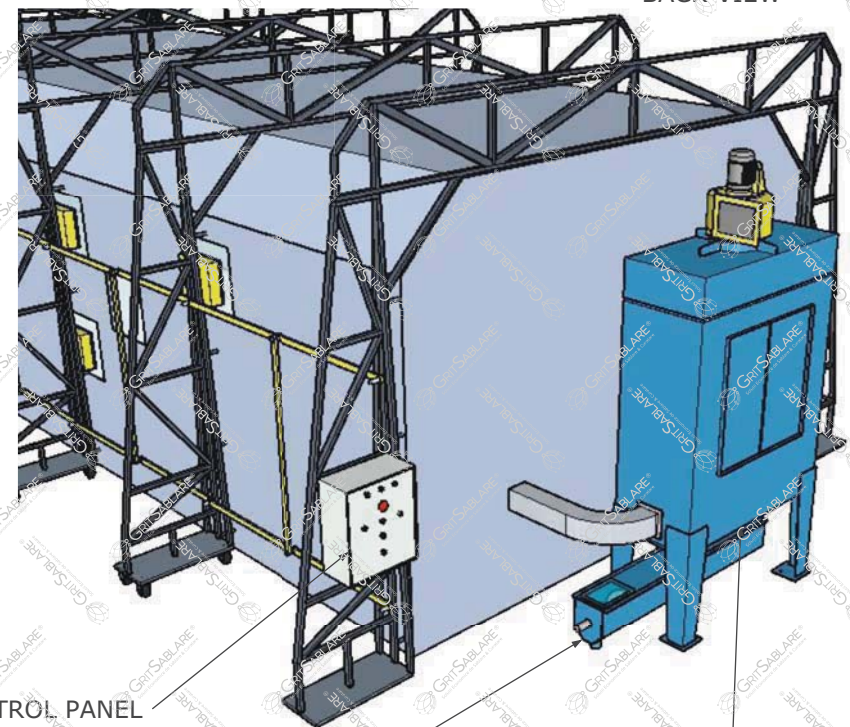

BACK VIEW

CONTROL PANEL

SCREW CONVEYOR

DUST EXTRACTOR

| PRODUCT DETAILS | |
|-----------------|-----------------|
| REFERENCE DWG | SI 425 |
| POWER SUPPLY | 415V 3PH, 50 HZ |
| POWER REQUIRED | 9.45 kW |
| AIR REQUIRED | NA |

BLAST ROOM DETAILS (EXTENDED)

ENCLOSURE DETAILS AS PER THE PAINT ROOM