



## ProFlo Abrasive Recycling System by GritSablare

### TECHNICAL DETAILS

#### Section 1. Product Description

- ProFlo Abrasive Recycling System by GritSablare is a manually loaded abrasive cleaning system combining an air wash stage with a screening system. The system is designed for use with a single pressure blast pot.
  - Fully adjustable abrasive air wash system removes dust.
  - Simple, efficient bucket elevator system.
  - Single cartridge dry dust collection system with reverse pulse cartridge purging.
  - 240 Volt single-phase electrical power.
  - Cleans garnet abrasive at 3,000 kg (6,600 lbs) per hour.
  - Compatible with most commercial abrasive types.
  - Optional stabilizer bars available for the elevator base plate frame.
- Common applications
  - Extend recyclable abrasive life.
  - Maintain abrasive efficiency by removing dust and debris.
  - Reduce operating costs.

#### Section 2. Complementary products

- |                           |                          |
|---------------------------|--------------------------|
| ▪ Pressure Blast Pots     | ▪ Pow Air Vac            |
| ▪ PBF Filter Cartridge    | ▪ Cosmo SAR              |
| ▪ PBF II-3 Airline Filter | ▪ Air Cooling Controller |
| ▪ Blast Hoses             | ▪ ATN Blast Nozzles      |



**ProFlo Abrasive Recycling System by GritSablare**

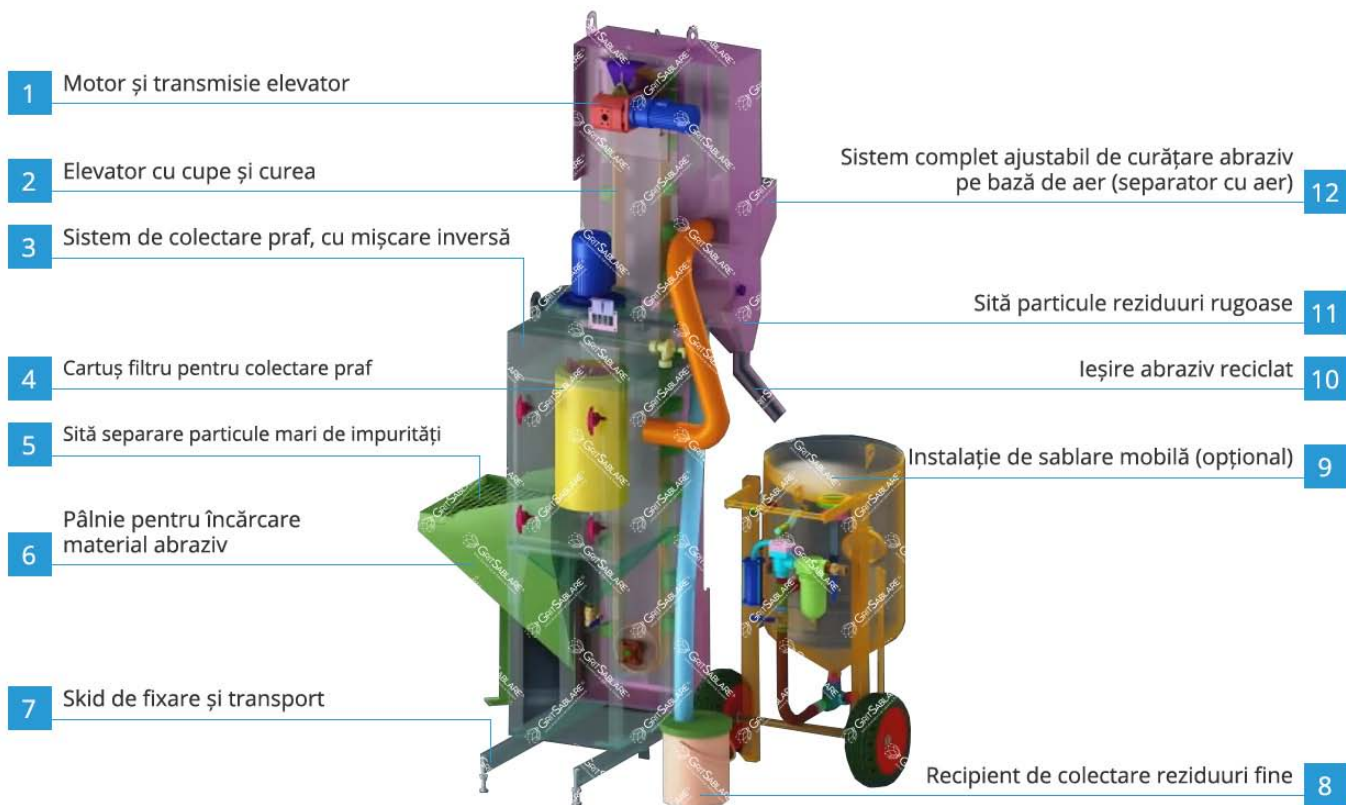

**ProFlo Abrasive Recycling System by GritSablare - Main Component**

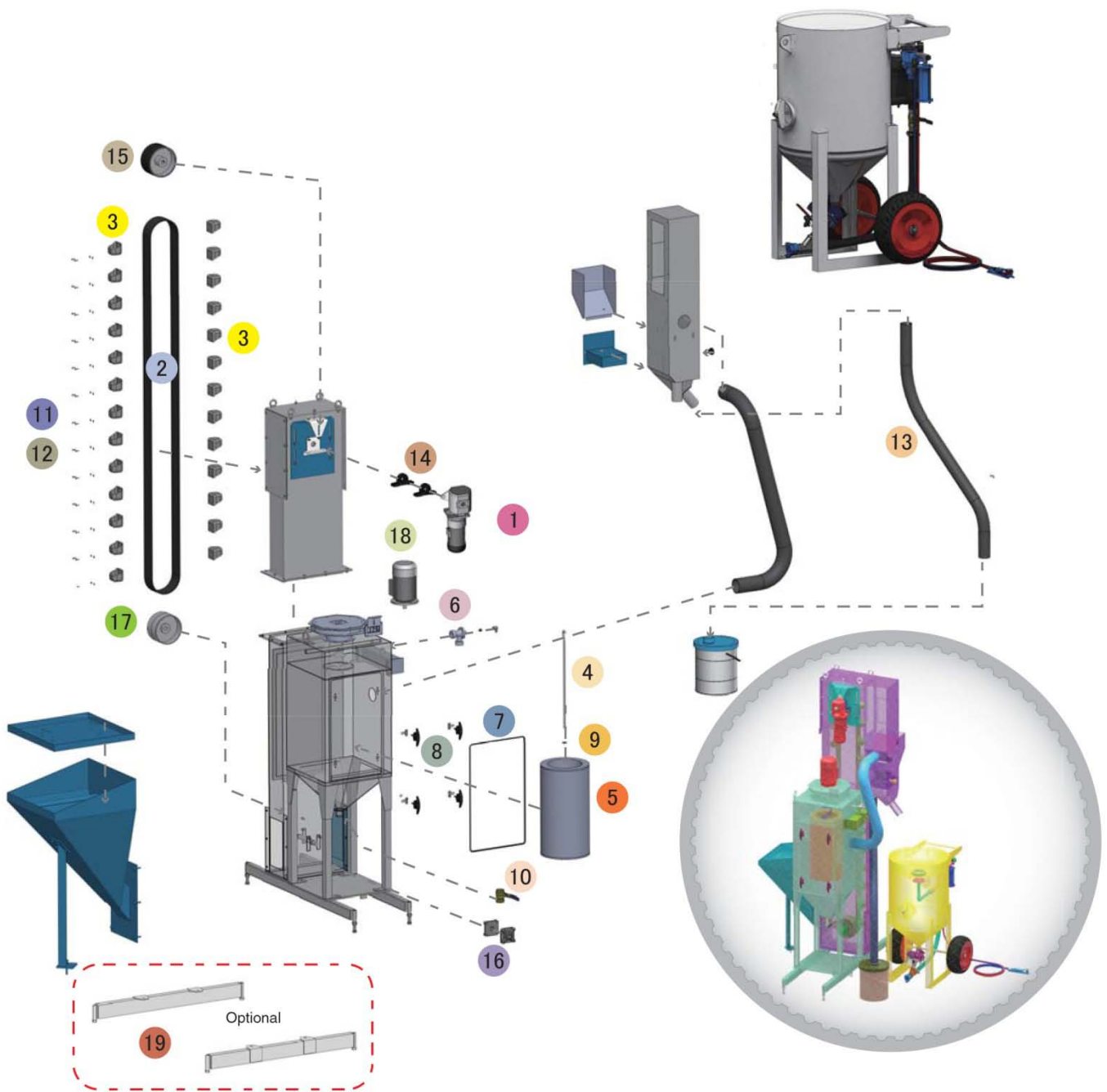



## Section 3. Product Operating Manual

---

### 1. GENERAL INFORMATION

#### 1.1. GritSablare notice to purchasers and users.

1.1.1. All products and equipment provided by GritSablare are intended for use by experienced users of abrasive blasting equipment and its associated operations and abrasive blasting media.

1.1.2. It is the responsibility of the user to:

- Determine if the equipment and abrasive media is suitable for the users' intended use and application.
- Familiarize themselves with any appropriate laws, regulations and safe working practices which may apply within the users' working environment.
- Provide appropriate operator training and a safe working environment including operator protective equipment such as, but not limited to, blasting suit, safety footwear, protective eyewear and hearing protection.

1.1.3. GritSablare Standard Terms and Conditions of Sale apply. Contact us should you require any further information or assistance.

#### 1.2. **! WARNING! – Read this section carefully before using this equipment**

1.2.1. Heavy metal paint, asbestos and other toxic material dusts will cause serious lung disease or death without the use of properly designed and approved supplied air respiratory (SAR) equipment by blast operators and all personnel within the work site area

1.2.2. The compressor must have adequate output and the plumbing between the compressor and the point of attaching the air supply hose must have sufficient capacity to supply the volume of air at the pressure required.

#### 1.3. Standard safety precautions

1.3.1. Approved safety eyewear, hearing and footwear protection should be worn at all times by the operator and anyone else in the immediate area that may be exposed to any hazards generated by the abrasive blasting process.

1.3.2. Suitably approved respiratory protection (PPE) should also be worn when handling abrasive media, abrasive refuse dust and when carrying out any service/maintenance work where any dust may be present.

1.3.3. Any work performed on electrical wiring or components must only be carried out by suitably qualified and registered electrical trade's personnel.

1.3.4. Under no circumstances should any safety interlocks / lockouts or features be altered or disabled in any way.

1.3.5. All equipment must be isolated from the compressed air supply and electrical power source prior to any service or maintenance work being carried out.

1.3.6. All care must be taken by the operator when lifting or moving equipment or components in order to prevent injury. Pressure Blast Pots must always be emptied of abrasive media before any attempt is made to move them.

1.3.7. Any modification of the equipment or use of non-genuine GritSablare replacement parts will void warranty.

1.3.8. Always check the Material Safety Data Sheet (MSDS) on the abrasive being used to ensure that it is free of harmful substances, in particular, free silica, cyanide, arsenic or lead.

1.3.9. Test the surface to be blasted for harmful substances, taking the appropriate measures to ensure the safety of all personnel.



- 1.3.10. The operator should carry out a daily inspection of all related components prior to startup of all wearing and safety items to ensure they are in correct operating order.

In particular check all Hose Couplings and Nozzle Holders, ensuring that all Hose Couplings are fitted correctly, the Safety Pins are engaged and in good order. Always install Safety Whip Check Cables at every hose connection. Ensure that the Blast Nozzle has been securely screwed into the Nozzle Holder and the Nozzle Holder has been secured to the Blast Hose correctly and all screws are engaged.

**NOTE: UNDER OSHA 1915:34(c)(1)(iv) DEAD MAN CONTROL. A DEADMAN CONTROL DEVICE SHALL BE PROVIDED AT THE NOZZLE END OF THE BLAST HOSE EITHER TO PROVIDE DIRECT CUTOFF OR TO SIGNAL THE POT TENDER BY MEANS OF A VISUAL AND AUDIBLE SIGNAL TO CUT OFF THE FLOW, IN THE EVENT THE BLASTER LOSES CONTROL OF THE HOSE. THE POT TENDER SHALL BE AVAILABLE AT ALL TIMES TO RESPOND IMMEDIATELY TO THE SIGNAL.**

## 2. ASSEMBLY INSTRUCTIONS

**NOTE: THE PROFLO ABRASIVE RECYCLING SYSTEM COMPONENTS ARE LARGE AND BULKY, AND THEREFORE MUST BE ASSEMBLED USING CORRECTLY SIZED OVERHEAD LIFTING EQUIPMENT, INCLUDING SUITABLY SIZED SLINGS/CHAINS AND SHACKLES. SOME COMMONLY AVIALBLE HAND TOOLS MAY BE REQUIRED FOR ASSEMBLY WORK. GRITSABLARE RECOMMENDS ONLY QUALIFIED TRADESMEN SHOULD ASSEMBLE THE UNIT.**

**! WARNING ! ALL LIFTING EQUIPMENT SUCH AS FORKLIFTS, MOBILE AND OVERHEAD CRANES AND OTHER LIFTING EQUIPMENT SHOULD ONLY BE OPERATED BY QUALIFIED PERSONNEL.**

- 2.1. The ProFlo Abrasive Recycling System is designed to be used on flat and level surfaces that provide a stable operating platform for the system. If the installation site is found to have an uneven surface, it is highly recommended that the optional Stabilizer Bar Assembly be used to ensure the stability of the unit.
- 2.2. The system is supplied in four (4) major components, as generally shown in Figure 1.
- 2.2.1. Bucket Elevator/Airwash Assembly.
- 2.2.2. Abrasive Load Hopper.
- 2.2.3. Base plate/Platform.
- 2.2.4. Cartridge Dust Collector Assembly.
- 2.2.5. An optional Stabilizer Bar Assembly is also available.
- 2.3. Place the baseplate on a flat level surface, with the four (4) jacking bolts facing downwards.
- 2.4. Attach suitably sized lifting slings/chains to the elevator lifting lugs, and using a forklift/overhead crane carefully lift the bucket elevator assembly into the vertical position, directly over the baseplate as shown in Figure 1.
- 2.5. Slowly lower the elevator into position on the baseplate and firmly attach the bucket elevator to the baseplate using the four (4) nuts and bolts provided. Tighten the bolts using properly sized spanners.
- 2.6. In the same manner, lift the cartridge dust collector assembly onto the baseplate, ensuring that the dust collector is orientated correctly i.e. with the dust collector inspection door facing away on the opposite side to the bucket elevator assembly.
- 2.7. Now carefully attach the abrasive loading hopper to the bottom flange on the elevator assembly as shown in Figure 1, using the bolts and gasket provided.
- 2.8. Loosen the loading hopper jacking bolt lock nut and adjust the jacking bolt to ensure that the hopper support leg is adjusted to the same level as the base plate.



- 2.9. Using a spirit level or similar, adjust the jacking bolts to ensure that the entire assembly is as level and as stable as possible.
- 2.10. Using the short length of flexible ducting provided, attach one end to the dust collector inlet spigot A, and the other end to the airwash separator spigot B. Firmly fix in position using the worm drive clamps provided.
- 2.11. Using the short length of flexible ducting, attach one end to the fine refuse discharge spout C, and the other end to the refuse bin lid spigot. Firmly fix in position using the worm drive clamps provided.
- 2.12. Plug the dust collector electrical cable connector to the receptacle on junction box mounted on the side of the elevator assembly.
- 2.13. Connect a 6mm (1/4") minimum compressed air supply to the dust collector pulse manifold, and tighten using a suitably sized spanner.
- 2.14. Connect the single-phase electrical power cable.
- 2.15. Position the fine refuse bin at floor level, directly adjacent to the dust collector, and fit the lid with the refuse hose attached.
- 2.16. The system is now ready for operation.
- 2.17. **Fitting of the optional stabilizer bar assembly:**
- 2.18. Remove the jacking bolts from the baseplate/platform.
- 2.19. Position a stabilizer bar across each end of the base plate/platform, bolt the stabilizer bar to the baseplate/platform using the M16 x125 LG bolts supplied, refer Figure 1.
- 2.20. Screw the M16 X 45 LG jacking bolts into the M16 nuts at each end of the stabilizer bars and level the unit.
- 2.21. When leveled, lock the jacking bolts with the lock nuts provided.

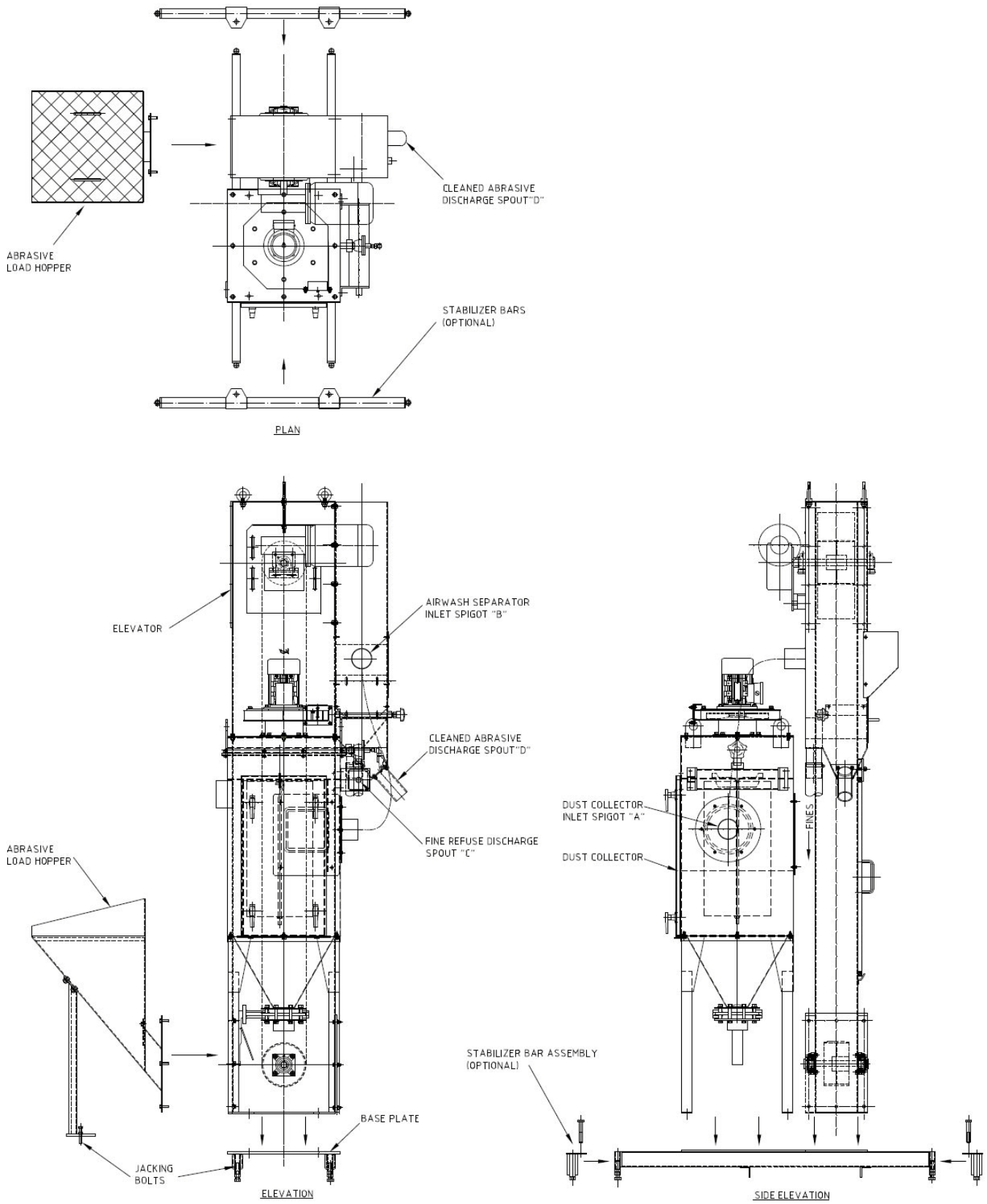

Figure 1

### 3. OPERATING INSTRUCTIONS

- 3.1.** Assemble the ProFlo Abrasive Recycling System as instructed in Section 2 of this manual.
- 3.2.** Prior to turning on the power supply to the ProFlo System, check the following items:
  - 3.2.1.** Check that the dust collector filter cartridge is centrally located in the dust collector housing, and that the retaining nut is tight on the hanger rod.
  - 3.2.2.** Ensure that the bucket elevator inspection door is on and locked in position.
  - 3.2.3.** Check that the dust collector drain valve located on the lower hopper is closed.
  - 3.2.4.** Ensure that the dust collector inspection door is on and locked in position.
  - 3.2.5.** Check all fasteners for tightness and correct location and the fitting of all system components.
- 3.3.** Remove the coarse debris screen from the abrasive loading hopper and check that the adjustable metering plate in the bottom of the abrasive load hopper is approximately 1/3 open. If necessary, loosen the lock nuts, adjust the metering plate into the correct position and retighten the lock nuts. Return the coarse debris screen into the abrasive load hopper.
- 3.4.** Because the condition of the abrasive to be processed will vary greatly depending on the amount of dust, fines and other contaminants, it will be necessary to adjust the airwash separator as shown in Figure 2.
- 3.5.** The airwash separator adjustment has four basic parameters.
- 3.6.** The primary baffle is vertically adjustable, and is used to control the amount of abrasive cascading over the separator airwash lip. The primary baffle should be adjusted so that when operating, the abrasive flows steadily over the lip, with a 25mm to 50mm (1" to 2") gap at each end of the abrasive curtain.
- 3.7.** The secondary baffle is used to control the amount of dust being drawn from the abrasive and across to the dust collector. The secondary baffle is also adjustable vertically. To reduce the amount of dust being carried over to the dust collector, the secondary baffle should be adjusted downwards. Conversely, to increase the amount of dust being removed from the abrasive, the secondary baffle should be adjusted upward.
- 3.8.** The skimmer plate is used to control the amount of fine waste (waste that is too large to be dust, but too fine to be good abrasive) being diverted to the fine refuse bin. The skimmer plate pivots on a shaft and is adjusted via an external handle mounted on the side of the airwash separator casing. To increase the amount of fine refuse being removed from the abrasive, unlock the handle and rotate it downwards and lock in position. To reduce the amount of fines being removed, unlock the handle and rotate it upwards and lock it in position.
- 3.9.** The dust collector fan baffle is used to vary the amount of airflow being moved by the dust collector fan. To increase the airflow the baffle opening should be increased, and to reduce the amount of airflow the baffle opening should be decreased.
- 3.10.** Position the blast pot (optional) directly below the clean abrasive discharge spout "D" shown in Figure 1.
- 3.11.** Turn on the mains power supply. The elevator drive motor and the dust collector fan motor should now both be operating.
- 3.12.** Commence loading the abrasive to be cleaned into the abrasive load hopper. As the abrasive drains through the opening in the bottom of the abrasive load hopper, the elevator will pick up the abrasive and elevate it to the top of the airwash separator.
- 3.13.** While the system is operating, the abrasive should cascade over the lip of the airwash, in a manner similar to a waterfall. Check that there is a gap at each end of the cascading abrasive curtain of approximately 25mm to 50mm (1" to 2").



- 3.14. As the abrasive passes down through the separator, the light dust will be drawn off to the dust collector and fine refuse which is sized between dust and good abrasive will be discharged through the fine refuse discharge spout down to the bin at floor level. Clean, reusable abrasive will be discharged to the blast pot for re-use.
- 3.15. The system is designed to clean a single pot load of abrasive at a time. Once the blast pot is full of cleaned abrasive, the ProFlo System should be turned off, otherwise the blast pot may become overfilled.
- 3.16. Once the first load of abrasive has been processed, visually check the condition of the cleaned abrasive in the blast pot, the amount of fines/dust in the fines waste bin, and the amount of dust in the dust collector hopper. Refer to the attached Figures 2 & 3 and section 3.5 above for separator adjustment and also refer to the Trouble Shooting Guide if required.
- 3.17. All adjustments should be small, incremental changes, made over an extended period of time, while monitoring the overall performance of the system.

### AIRWASH SEPARATOR

FIGURE 2

FIGURE 3

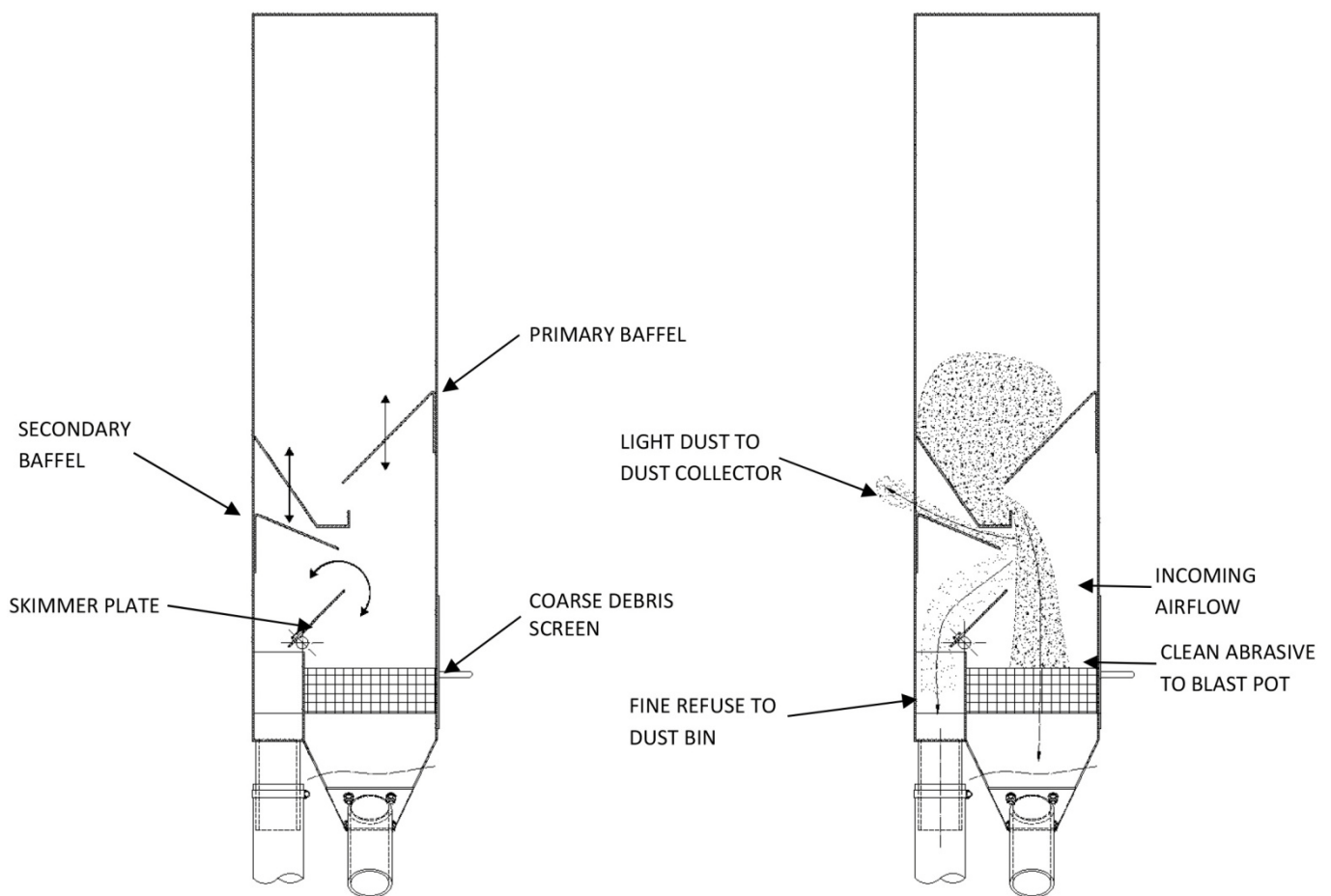

AIRWASH SEPARATOR ADJUSTMENTS

ABRASIVE FLOW THROUGH SEPARATOR

## 4. MAINTENANCE

### 4.1. On a daily basis:

- 4.1.1. Empty the fine refuse waste bin. Depending on the duty cycle of the system, it may be necessary to empty the waste bin several times per day.
- 4.1.2. Operate the dust collector valve 2 - 3 times, and then open the dust collector drain valve to drain the waste dust from the dust collector hopper. Again, depending on the duty cycle it may be necessary to drain the dust collector several times per day.

**NOTE: EXCESSIVE OVER PURGING OF THE DUST COLLECTOR FILTER CARTRIDGE WILL CAUSE DAMAGE TO THE CARTRIDGE, WHICH MAY CAUSE THE SYSTEM TO LEAK DUST. IT IS NORMAL FOR A LAYER OF DUST TO BE PRESENT ON THE FILTER CARTRIDGE AT ANY TIME.**

- 4.1.3. Remove and clean the airwash separator coarse debris screen, and check for signs of wear on the screen mesh. Replace the mesh as necessary.
- 4.1.4. Visually check all inspection door seals, fasteners and latches. All inspection door seals should form an airtight seal. Replace seals as necessary.

### 4.2. On a weekly basis

- 4.2.1. Visually inspect all hoses/ducting for signs of wear and/or deterioration, and replace as necessary.
- 4.2.2. Check for any signs of air leakage on the hose connection between the airwash separator and the dust collector. Rectify as required.

### 4.3. On a monthly basis

- 4.3.1. Remove the elevator side inspection door and check for the condition of the elevator buckets and belt. The buckets are manufactured from pressed steel, and the front edge will wear over a period of time. Replace any buckets which show wear in excess of approximately 12mm (1/2").
- 4.3.2. Check and inspect the condition and tension of the elevator belt. Elevator belt free play should not exceed approximately 100mm (4").
- 4.3.3. To adjust the belt tension, loosen the take up lock nuts on both sides of the elevator upper casing, and then screw the take up bottom nuts downwards by rotating them in the clockwise direction.
- 4.3.4. Slowly turn the take up top nuts in the clockwise direction, which will raise the elevator take up and drive assembly and increase the tension on the elevator belt.
- 4.3.5. Use the take up mechanism to ensure that the elevator belt is tracking in the centre of the elevator pulley. Increasing the tension on one side of the take up will cause the belt to move away towards the opposite side of the elevator casing.
- 4.3.6. Once the correct tension has been achieved, and the belt is tracking centrally, lock the take up in position by re-tightening the take up lock nuts.

**! WARNING ! - NEVER OPERATE THE ELEVATOR WITH ANY OF THE INSPECTION DOORS OR COVERS REMOVED, AS THIS MAY RESULT IN SERIOUS INJURY OR DEATH.**

- 4.3.7. Visually inspect all bearings and drive unit, and listen for any unusual noises during operation. Replace worn bearings as necessary.



## 5. TROUBLE SHOOTING GUIDE

<b>Problem</b>	<b>Possible Cause</b>	<b>Probable Solution</b>
1 Excessive dust and fines in cleaned abrasive.	Secondary baffle plate set too low.	Adjust secondary baffle plate upwards.
	Insufficient airflow from dust collector.	Increase opening on dust collector fan baffle.
	Blocked/dirty filter cartridge.	Clean/replace filter cartridge.
	Dust collector drain valve open.	Close drain valve.
	Skimmer plate setting too high.	Adjust skimmer plate downwards.
	Air leak between dust collector and airwash separator.	Check for leaks and rectify.
2 Good abrasive carried over to dust collector.	Excessive abrasive flow through separator.	Adjust primary baffle downwards.
	Secondary baffle plate set too high.	Adjust secondary baffle plate downwards.
3 Good abrasive in fines refuse bin.	Excessive airflow from dust collector.	Slightly close dust collector fan baffle.
	Skimmer plate set too low.	Adjust skimmer plate upwards.
	Coarse debris screen blocked.	Remove screen and clean.
	Clean abrasive discharge spout blocked.	Check for blockage or overfilled blast pot.



## 6. ASSEMBLIES, PART LISTING, EXPLODED VIEW

### 6.1. ProFlo Abrasive Recycling System Assemblies

Code	Description	Quantity
BEB-AR-PB-0001	ProFlo Abrasive Recycling System (Items 1-3,5-11,14-16,18-21)	550 kg (1213 lbs)
BEB-AR-0057-00	Extended ProFlo Recycling System (Items 1, 3-11, 13-15,17,18-21)	780 kg (1720 lbs)
BEB-AR-0058-00	Extended ProFlo Recycling System Hopper (Item 22)	160 kg (353 lbs)
BEB-AR-0059-00	Ext ProFlo System W/ Storage Hopper (Items 1, 3-11, 13-15,17,18-22)	940 kg (2073 lbs)

### 6.2. ProFlo Abrasive Recycling System Parts Listing

Item	Code	Description	Quantity
1	YEB-AE-0034-00	230VAC 1PH 50HZ Motor	1
2	BEB-AE-PB-0021	4Ply 100mm X 5.66m Elevator Belt	1
3	BEB-AE-PB-0029	Elevator Bucket	37 for Standard 42 for Extended
4	BEB-AE-0053-00	Elevator Belt	1
5	YAC-DC-PB-0005	700mm Hanger Rod	1
6	BAC-DF-PB-0002	Filter Cartridge - Size 2(Open/Close)	1
7	BAC-DC-PB-0007	Pulse Valve	1
8	YAC-CA-PB-0375	Dust Collector Door Seal	2.3 m
9	YAC-CA-PB-0205	Handle Tongue	4
10	BAC-DC-PB-0001	Filter Cartridge Washer	1
11	BAC-PF-0344-00	Butterfly Valve - 4 "	1
12	YEB-AE-0036-00	Stabilizer Bar	2
13	YAC-AR-0048-00	Extended Section	1
14	YAC-FN-0356-00	M6 Bolt - Special	74 for Standard 84 for Extended
15	YAC-FN-0357-00	Washer - Special	74 for Standard 84 for Extended
16	YEB-AR-0005-01	Recovery Hose	1
17	YEB-AR-0060-00	Recovery Hose	1
18	YEB-AE-PB-0027	Block Bearing	2
19	YEB-AE-PB-0009	Crown Pulley Lagged	1
20	YEB-AE-0035-00	Flange Bearing	2
21	YEB-AE-PB-0010	Crown Pulley	1
22	BEB-AR-0058-00	Ext ProFlo Recycling System Hopper	1

### 6.3. ProFlo Abrasive Recycling System Service Kit

Item	Code	Description	Quantity
1	YEB-AE-0034-00	230VAC 1PH 50HZ Motor	1

### 6.4. Pow Air Vac Exploded View

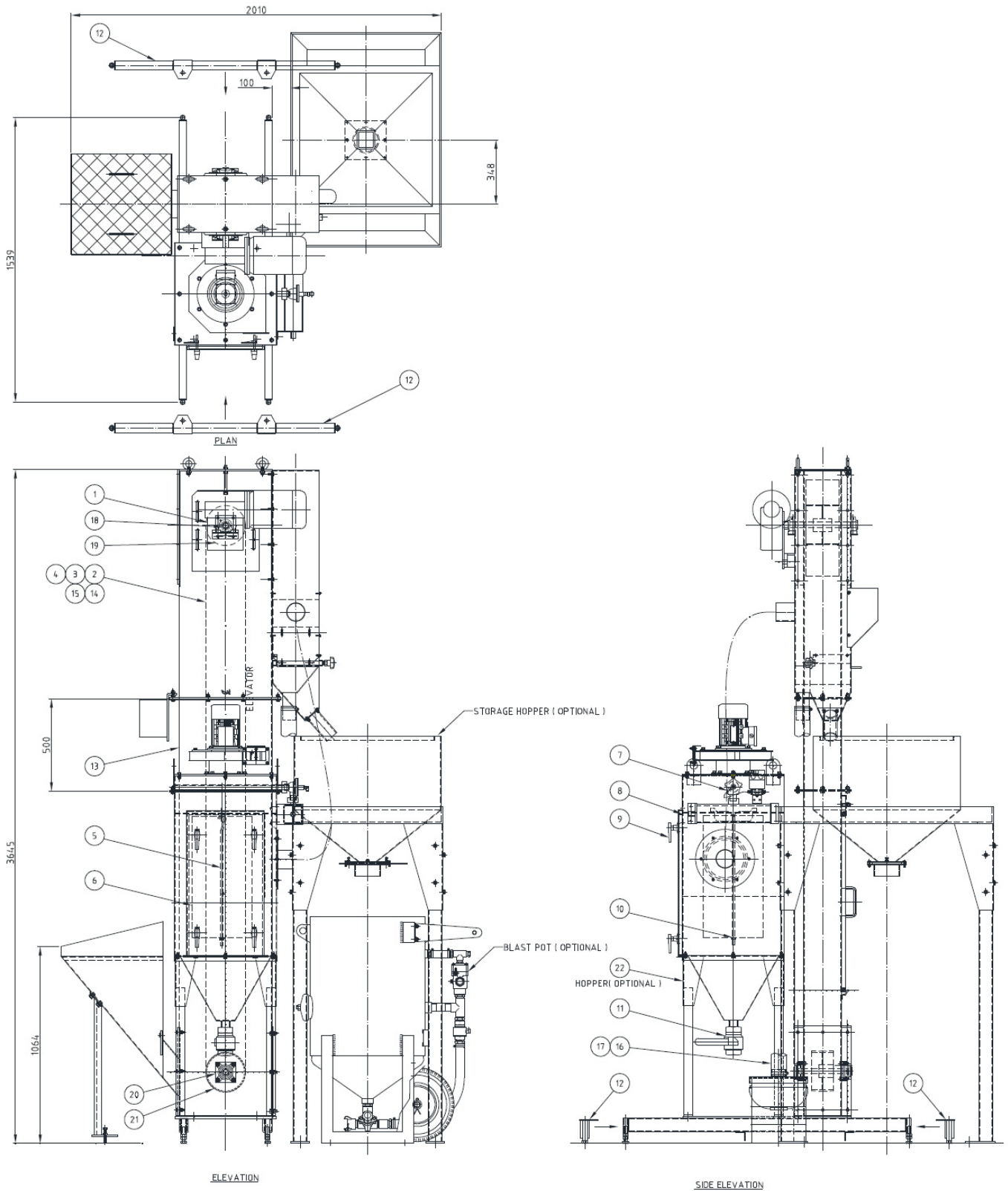



## 7. CIRCUIT DIAGRAM

### 7.1. ProFlo Abrasive Recycling System Circuit Diagram

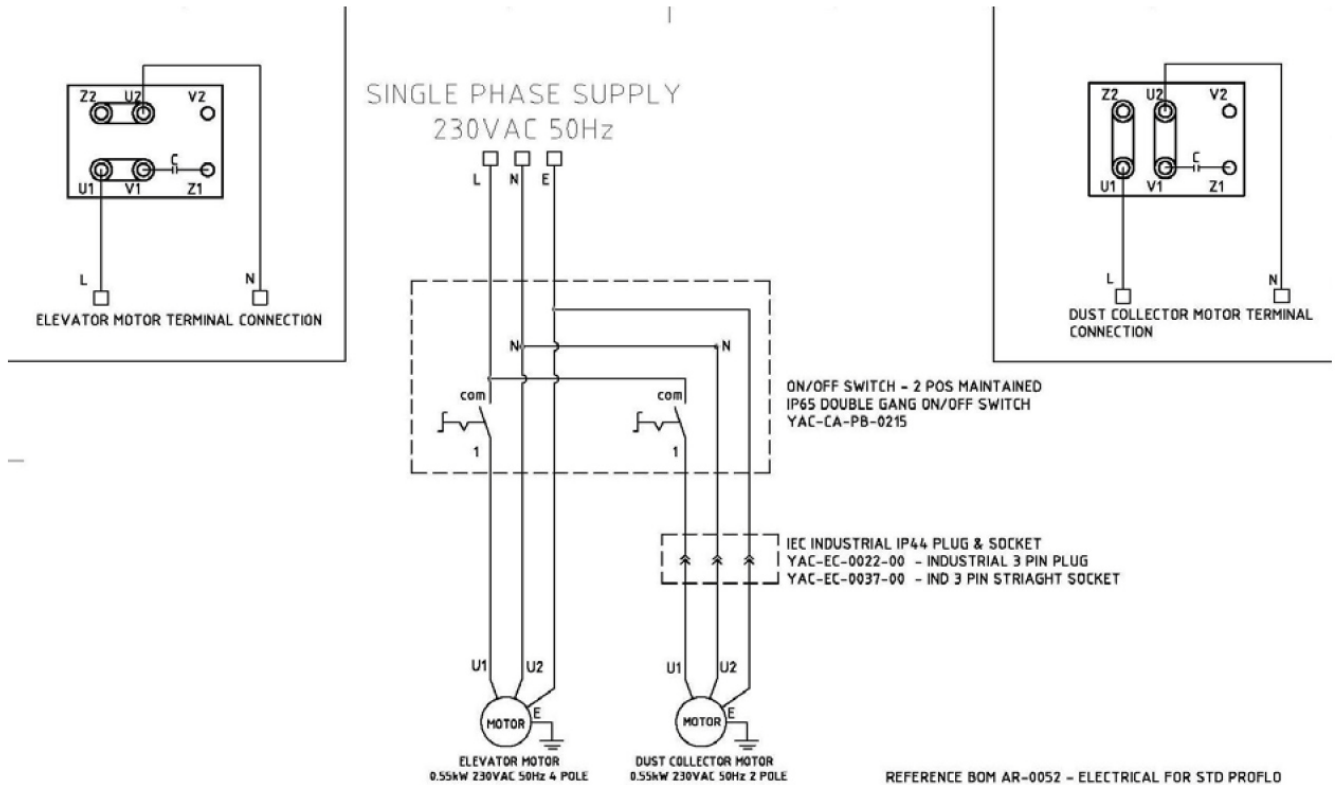

## Section 4. Product Identification

Product name	ProFlo Abrasive Recycling System by GritSablare
Distributor:	<b>GritSablare</b>
Headquarter:	10 Eliza Zamfirescu Leonida Street, Bucharest
Storage & Logistic:	Constanța Seaport, Gate 2, SORENA Platform, Constanța, Romania
Phone:	(+4) 0722.279.481
Email:	comercialgritsablare@gmail.com
Website:	www.gritsablare.ro